

Kensington®

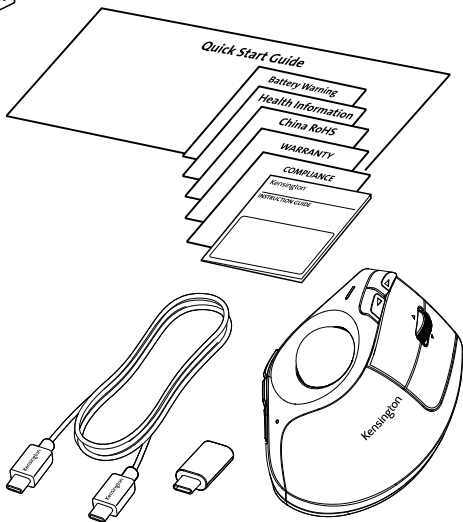

Pro Fit™ Ergo TB675 Vertical Wireless Trackball Boule de commande sans fil verticale Pro Fit™ Ergo TB675



[kensington.com/register](https://www.kensington.com/register)

1

Left Click | Clic gauche |
Linksklick | Clic pulsante
sinistro | Clic izquierdo |
Clique com o Botão
Esquerdo |

نقر بزر الماوس الأيسر |
左クリック | 左键单击

Forward | Retour |
Commande d'avance |
Vorwärts | Avanti |
Adelante | Avançar |
التالي | 進む | 前进

Status Indicator |
Indicateur d'état |
Indicateur d'état |
Statusanzeige |
Állapotjelző fény |
Sindikátor stavu |
Indicador de estado |
مؤشر الحالة |
状態指示灯 |
ステータス インジケ
ーター

Backward | Avance |
Commande de retour |
Rückwärts | Indietro |
Atrás | Retroceder |
رجوع | 戻る | 后退

Middle-Click Button/Scroll Wheel/Scroll
Left/Scroll Right | Clic central/Molette de
défilement/Défilement gauche/
Défilement droit | Bouton de clic central/
Molette de défilement/Défilement vers la
gauche/Défilement vers la droite |
Mittlere Maustaste/Scrollrad/Nach links
scrollen/Nach rechts scrollen | Pulsante
centrale/Rotella di scorrimento/
Scorrimento a sinistra/Scorrimento a
destra | Botón de clic intermedio / Rueda
de desplazamiento / Desplazamiento a la
izquierda / Desplazamiento a la derecha |
Botão do meio do rato/Roda de rolagem/
Rolar para a esquerda/Rolar para a direita |
زر النقر الأوسط / عجلة التمرير / التمرير لليمين |

ミドルクリックボタン/スクロールホイール/
左スクロール/右スクロール |
中键/滚轮/向左倾/向右倾

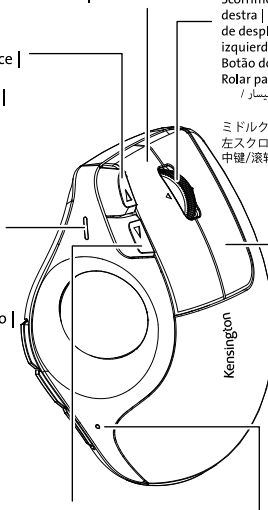

Right Click | Clic droit |
Rechtsklick | Clic
pulsante destro |
Clic derecho |
Clique com o Botão
Direito | نقر بزر الماوس الأيمن |
右クリック | 右键单击

DPI Indicator |
Indicateur de DPI |
Indicateur PPP |
DPI-Anzeige |
Indicatore DPI |
Indicador DPI |
Indicador DPI |
DPI مؤشر |
DPIインジケーター |
DPI 指示灯

Trackball Ejection Button |
 Bouton d'éjection de la boule de commande |
 Bouton d'éjection du trackball |
 Taste zum Herauslösen der Trackball-Kugel |
 Pulsante disinserimento trackball |
 Botón de expulsión del trackball |
 Botão de ejeção de trackball |
 زر إخراج كرة التعقب | ボール取り出しボタン |
 轨道球弹出按钮 |

Channel Selection/
 Bluetooth Pairing button |
 Sélection de canal/Bouton de
 couplage Bluetooth |
 Bouton de sélection de canal/
 Appairage Bluetooth |
 Kanalauswahl/Bluetooth-
 koppeln-Taste | Pulsante di
 selezione del canale/associazione
 Bluetooth | Botón de selección de
 canal / emparejamiento Bluetooth |
 Botão de seleção de canal /
 emparelhamento Bluetooth |
 زر اقتتان البلوتوث / اختيار القناة | 接続方式
 選択/Bluetoothペアリングボタン |
 连接模式选择/蓝牙配对按钮

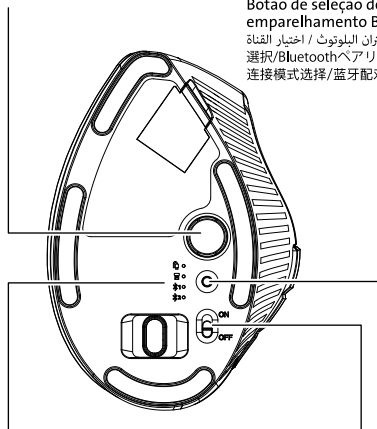

Channel Indicator |
 Indicateur de canal |
 Indicateur de canal |
 Kanalanzeige |
 Indicatore del canale |
 Indicador de canal |
 Indicador de canal |
 مؤشر القناة |
 接続インジケータ |
 连接模式指示灯

On/Off Switch | Interrupteur
 marche/arrêt | Interrupteur
 Marche/Arrêt | Ein/Aus-Schalter |
 Interruttore di
 accensione/spengimento |
 Botão de ligar/desligar |
 مفتاح التشغيل/إيقاف التشغيل |
 電源スイッチ | 开关

Customizable with Kensington Connect™ /
Personnalisable avec Kensington Connect™ /
Anpassbar mit Kensington Connect™ /
Personalizzabile con Kensington Connect™ /
Personalizable con Kensington Connect™ /
Personalizável com Kensington Connect™ /
可通过 Kensington Connect™ 进行定制 /
Kensington Connect™ でカスタマイズ可能 /
Kensington Connect™ قابل للتخصيص باستخدام

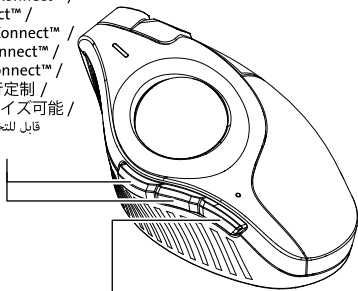

DPI Switch Button |
Bouton de sélection de DPI |
Bouton de commutation PPP |
DPI-Umschalttaste |
Pulsante per la selezione dei DPI |
Botón del interruptor DPI |
Botão comutador de DPI |
DPI 切换按钮 | DPI切り替えボタン |
DPI 切换按钮

2

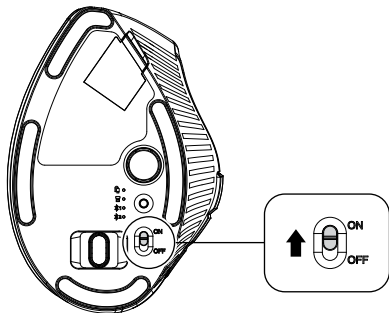

3

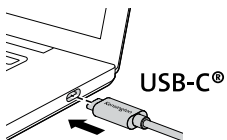
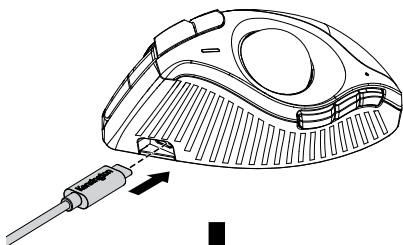

White | Weiß | Blanc |
Blanco | Bianco | Branco
أبيض | 白色 | 白 | Blanc

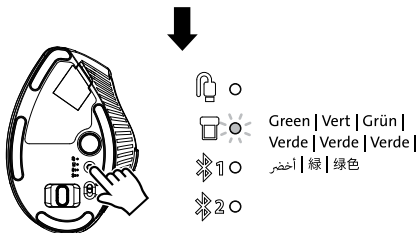
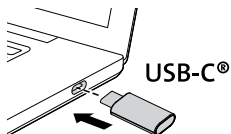
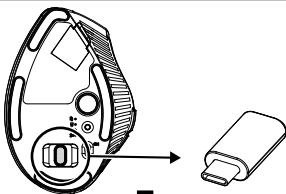

* Flashing Green: Not connected | * Vert clignotant : non connecté |
* Vert clignotant :Non connecté | * Grün blinkend: Nicht verbunden |
* Verde lampeggiante: non connesso | * Verde parpadeante:
no conectado | * Verde intermitente:Não ligado |

* أخضر وامض: غير متصل | * 緑で点滅: 接続されていない | * 绿灯
闪烁:未连接

Bluetooth®

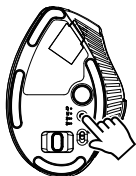

or

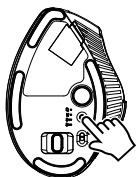
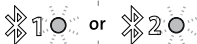
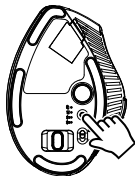

3 sec

Fast Flashing Blue: Pairing Mode |
 Clignotement rapide en bleu : mode de couplage |
 Bleu clignotant rapidement : Mode d'appairage |
 Blau schnell blinkend: Kopplungsmodus |
 Lampeggio rapido in blu: modalità di associazione |
 Azul parpadeante rápido: Modo de emparejamiento |
 Azul intermitente rápido: Modo de emparelhamento |
 أزرق وامض بسرعة: وضع الاقتران | 青で急速点滅: ペアリングモード |
 蓝灯快闪: 配对模式

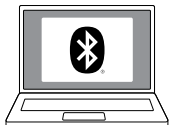
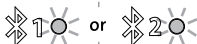

Solid Blue: Connected | Bleu fixe :
 connecté | Bleu fixe : Connecté | Blau
 konstant leuchtend: Verbunden | Luce
 blu fissa: connesso | Azul constante:
 Conectado | Azul fixo: Ligado | أزرق ثابت: متصل |
 青で点灯: 接続中 | 蓝灯常亮: 已连接



* Slow Flashing Blue: Not connected | * Clignotement lent en bleu:
 non connecté | * Bleu clignotant lentement : Non connecté | * Blau
 langsam blinkend: Nicht verbunden | * Lampeggio lento in blu:
 Non connesso | * Azul parpadeante lento: No conectado |

-- or --



* Azul intermitente lento: Não ligado | * أزرق وامض ببطء: غير متصل |
 * 青でゆっくりと点滅: 接続されていない | * 蓝灯慢闪: 未连接

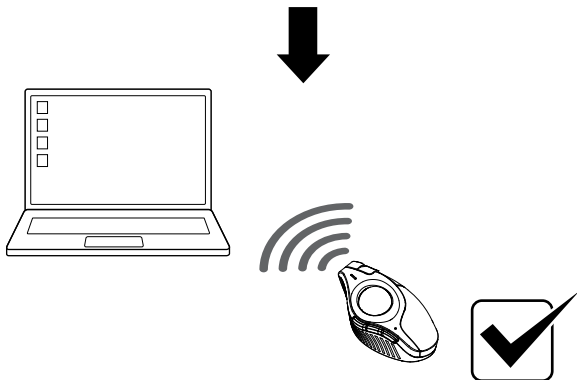

4



www.Kensington.com/software/hub

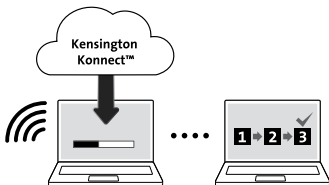

Compatibility | Kompatibilität | Compatibilit  | Compatibilidad |
Compatibilit  | Compatibilidade | التوافق | 兼容性 | 互換性 |
Compatibilit  | 相容性 | 호환성 :

Windows, macOS®

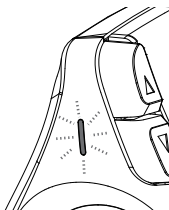

Flashing Red: Low Battery |
Rouge clignotant : batterie faible |
Clignotement rouge : Batterie faible |
Blinkt rot: Akku schwach |
Rosso lampeggiante: batteria scarica |
Rojo parpadeante: batería baja |
Vermelho Intermitente: Bateria Fraca |
أحمر وامض: بطارية منخفضة |
赤で点滅: バッテリー容量低下 |
红灯闪烁: 电池电量低

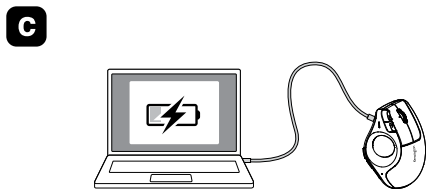
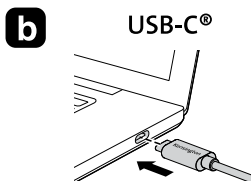
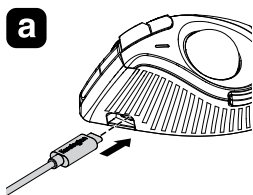

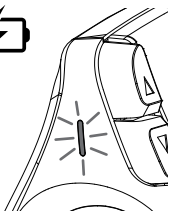

Solid Red: Charging |
Rouge fixe : charge en cours |
Rouge fixe : En charge |
Rot konstant leuchtend: Laden |
Luce rossa fissa: Ricarica |
Rojo constante: Carga |
Vermelho fixo: Em carregamento |
أحمر ثابت: الشحن | 赤で点灯: 充電中 |
红灯常亮: 充电中



Solid Green: Fully Charged |
Vert fixe : pleinement chargée |
Vert fixe : Complètement chargé |
Grün konstant leuchtend:
Vollständig geladen |
Luce verde fissa: ricarica completata |
Verde constante:
Completamente cargado |
Verde fixo: Totalmente carregado |
أخضر ثابت: مشحون بالكامل |
緑で点灯: フル充電状態 | 绿灯常亮: 已充满

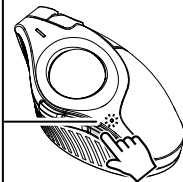
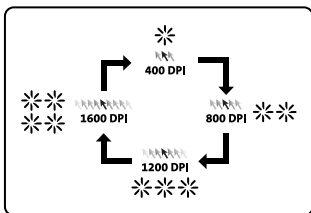



NOTICE / AVIS

Battery Disassembly Instructions /
Instructions relatives au démontage de la batterie



1

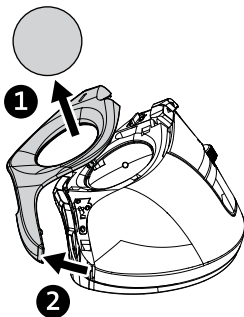

2

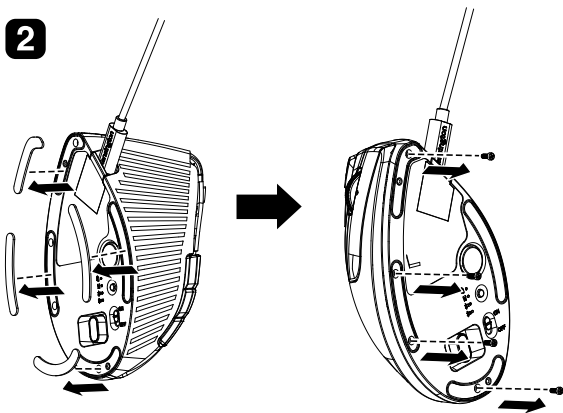

3

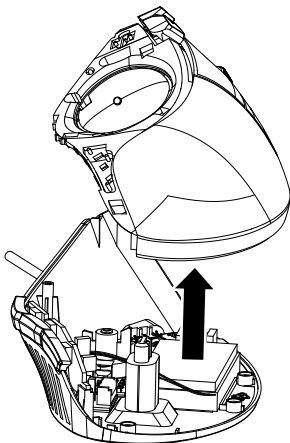
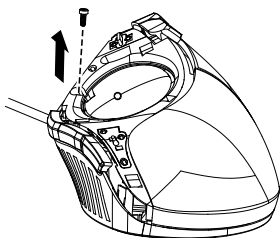

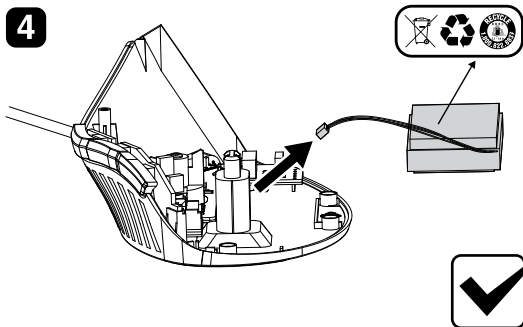
4

EN Lithium-ion Polymer Battery (NMC)
FR-CA Batterie lithium-ion polymère (NMC)
DE Lithium-Ionen-Polymer-Akku (NMC)
FR Batterie Lithium-ion polymère (NMC)
IT Batteria polimerica agli ioni di litio (NMC)
ES Polímero de iones de litio (NMC)

PT Bateria de polímero de iões de lítio (NMC)
CN 鋰聚合物電池(NMC)
JP リチウムイオン電池 (NMC)
TW 鋰聚合物電池(NMC)
KO 리튬이온 폴리머 배터리(NMC)
AE بطارية ليثيوم أيون بوليمر (أكسيد الليثيوم كوبالت)

EN This device is not equipped with a replaceable battery. Attempts to remove or replace the battery will void the warranty and may damage the device. When disposing or recycling this device, the battery should be disposed of in a manner compliant with local battery disposal regulations.

FR-CA Cet appareil n'est pas équipé d'une batterie remplaçable. Toute tentative de retrait ou de remplacement de la batterie annulera la garantie et pourrait endommager l'appareil. Lors de la mise au rebut ou du recyclage de cet appareil, la batterie doit être éliminée conformément aux réglementations locales en matière d'élimination des batteries.

DE Dieses Gerät ist nicht mit einem austauschbaren Akku ausgestattet. Der Versuch, den Akku zu entfernen oder zu ersetzen, führt zum Erlöschen der Garantie und kann das Gerät beschädigen. Wenn Sie dieses Gerät entsorgen oder recyceln, müssen Sie den Akku so entsorgen, dass dies den örtlichen Vorschriften für die Entsorgung von Akkus entspricht.

FR Cet appareil n'est pas doté d'une batterie remplaçable. Toute tentative de retrait ou de remplacement de la batterie aura pour effet d'annuler la garantie et pourraient endommager l'appareil. Lors de la mise au rebut ou du recyclage de cet appareil, la batterie doit être éliminée conformément aux réglementations locales applicables aux batteries.

IT Questo dispositivo non è dotato di batterie sostituibili. Qualsiasi tentativo di rimozione o sostituzione della batteria annullano la garanzia e possono danneggiare il dispositivo. Al momento dello smaltimento o del riciclaggio del dispositivo, smaltire la batteria in conformità alle normative locali sullo smaltimento delle batterie

ES Este dispositivo no está equipado con una batería reemplazable. Los intentos de retirar o sustituir la batería anularán la garantía y podrían dañar el dispositivo. Al eliminar o reciclar este dispositivo, la batería debe eliminarse de forma que cumpla la normativa local sobre eliminación de baterías.

PT Este dispositivo não está equipado com uma bateria substituível. As tentativas de remoção ou substituição da bateria anularão a garantia e poderão danificar o dispositivo. Ao eliminar ou reciclar este dispositivo, a bateria deve ser eliminada em conformidade com os seus regulamentos locais relativos à eliminação de baterias.

CN 本设备不配备可更换电池。擅自拆除或更换电池，保修一概失效，并可能造成设备损坏。处置或回收本设备时，应按当地处置电池的相关法规处置。

JP このデバイスには、交換可能なバッテリーは搭載されていません。バッテリーの取り外しや交換を試みると、保証が無効になり、デバイスを損傷させる恐れがあります。本デバイスを廃棄またはリサイクルする場合、バッテリーは地域のバッテリー廃棄規則に準拠した方法で廃棄してください。

AE

هذا الجهاز غير مزود ببطارية قابلة للاستبدال. وستؤدي محاولات إزالة البطارية أو استبدالها إلى إلغاء الضمان وقد تؤدي إلى تلف الجهاز. وعند التخلص من هذا الجهاز أو إعادة تدويره، يجب التخلص من البطارية بطريقة تتوافق مع اللوائح المحلية للتخلص من البطاريات.



www.kensington.com/support

Kensington® and Pro Fit™ are trademarks of ACCO Brands. macOS is a trademark of Apple Inc. registered in the U.S. and other countries. Windows is a registered trademark of Microsoft Corporation in the U.S. and/or other countries. The Bluetooth® word mark and logos are registered trademarks owned by Bluetooth SIG, Inc. USB-C® is a trademark of USB Implementers Forum. All other registered and unregistered trademarks are the property of their respective owners.

© 2026 Kensington Computer Products Group, a division of ACCO Brands.
Patents: <https://www.accobrand.com/patents/>

Kensington® et Pro Fit™ sont des marques d'ACCO Brands. macOS est une marque d'Apple Inc. aux États-Unis et dans d'autres pays. Windows est une marque déposée de Microsoft Corporation aux États-Unis et/ou dans d'autres pays. La marque verbale et les logos Bluetooth® sont des marques déposées appartenant à Bluetooth SIG, Inc. USB-C® est une marque déposée de l'USB Implementers Forum. Toutes les autres marques déposées et non déposées sont la propriété de leurs détenteurs respectifs.

© 2026 Kensington Computer Products Group, une division d'ACCO Brands.
Brevets : <https://www.accobrand.com/patents/>

Pro Fit™ Ergo TB675 Vertical Wireless Trackball
M/N: M01764-T
Rating: 5V ===500mA
Operating Frequency: 2.402-2.480Ghz.

Wireless Dongle
M/N: M01764-D
Rating: 5V ===20mA



Energy Verified
Rendement
Énergétique Vérifié



R 220-
J10894



R 220-
J10893

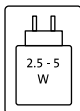

Complies with
IMDA Standards
DB105685

